

ITEM NO.	PART NUMBER	DESCRIPTION	QTY.
1	COV375420-1		1
2	4200-S5	4200-S5	2
3	375ALLTHREAD	3/8-16 x 1.25 ALL THREAD	2

REV	ZONE	DESCRIPTION	DATE	ENG
	-	INITIAL DESIGN	3-27-14	JAS

NOTES:

1. MATERIAL: .125 THICK POLYCARBONATE
2. DEBURR EDGES
3. FINISH: NONE

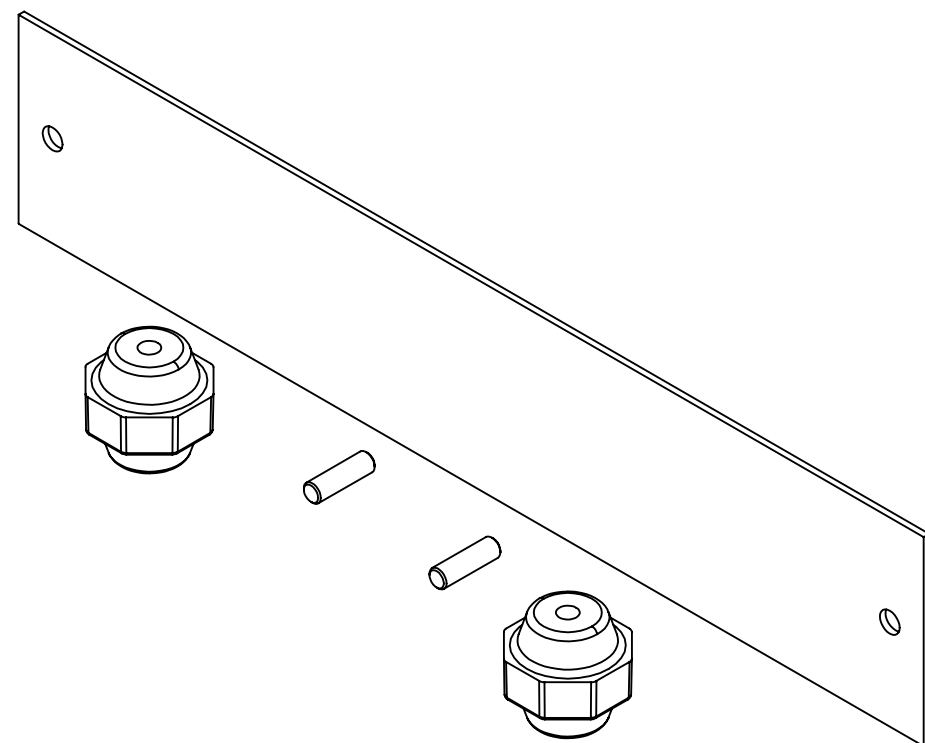
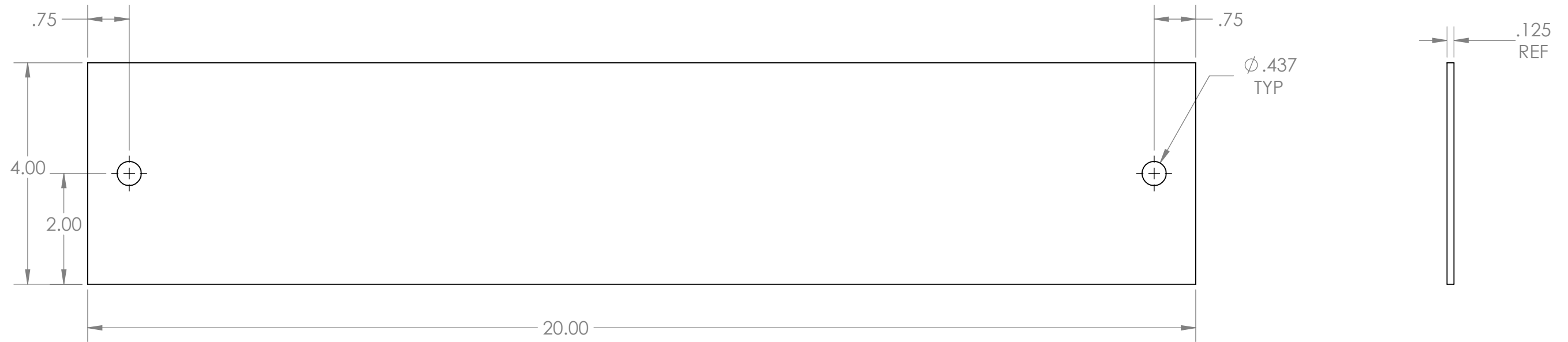

UNLESS OTHERWISE SPECIFIED:		NAME	DATE
DIMENSIONS ARE IN INCHES		DRAWN	JAS 3-27-14
TOLERANCES:		CHECKED	
ANGULAR: BEND $\pm 1^\circ$		ENG APPR.	
ONE PLACE DECIMAL $\pm .1$		MFG APPR.	
TWO PLACE DECIMAL $\pm .021$		Q.A.	
THREE PLACE DECIMAL $\pm .005$		COMMENTS:	
INTERPRET GEOMETRIC TOLERANCING PER:			
MATERIAL: SEE NOTES			
FINISH: SEE NOTES			
DO NOT SCALE DRAWING			

		TITLE:	
		COVER-375-20	
SIZE	DWG. NO.	REV	
B	COV375420-1-KT	1	
SCALE: 1:2	WEIGHT:	SHEET 1 OF 1	